



ICs for Communications

ISDN High Voltage Power Controller
IHPC

PEB 2026 Version 1.1

Data Sheet 09.99

DS 2

PEB 2026		
Revision History:		Current Version: 09.99
Previous Version:		preliminary Data Sheet 02.96
Page (in previous Version)	Page (in current Version)	Subjects (major changes since last revision)
	3-2	Information added about thermal protection and life time
	3-3	Information added about parasitic diodes
	3-3	Extra paragraph for subject " I_{BAT} current peak"
16	7-1	Some values for absolute maximum ratings are extended/adapted.
17	7-4	The static thermal resistances are updated. The last two paragraphs on this page, explaining the reason for the different packages are additional.

For questions on technology, delivery and prices please contact the Infineon Technologies Offices in Germany or the Infineon Technologies Companies and Representatives worldwide:
see our webpage at <http://www.infineon.com>

ABM®, AOP®, ARCOFI®, ARCOFI®-BA, ARCOFI®-SP, DigiTape®, EPIC®-1, EPIC®-S, ELIC®, FALC®54, FALC®56, FALC®-E1, FALC®-LH, IDEC®, IOM®, IOM®-1, IOM®-2, IPAT®-2, ISAC®-P, ISAC®-S, ISAC®-S TE, ISAC®-P TE, ITAC®, IWE®, MUSAC®-A, OCTAT®-P, QUAT®-S, SICAT®, SICOFI®, SICOFI®-2, SICOFI®-4, SICOFI®-4μC, SLICOFI® are registered trademarks of Infineon Technologies AG.

ACE™, ASM™, ASP™, POTSWIRE™, QuadFALC™, SCOUT™ are trademarks of Infineon Technologies AG.

Edition 09.99

**Published by Infineon Technologies AG,
TR,
Balanstraße 73,
81541 München**

© Infineon Technologies AG 1999.
All Rights Reserved.

Attention please!

As far as patents or other rights of third parties are concerned, liability is only assumed for components, not for applications, processes and circuits implemented within components or assemblies.

The information describes the type of component and shall not be considered as assured characteristics.

Terms of delivery and rights to change design reserved.

Due to technical requirements components may contain dangerous substances. For information on the types in question please contact your nearest Infineon Technologies Office.

Infineon Technologies AG is an approved CECC manufacturer.

Packing

Please use the recycling operators known to you. We can also help you – get in touch with your nearest sales office. By agreement we will take packing material back, if it is sorted. You must bear the costs of transport.

For packing material that is returned to us unsorted or which we are not obliged to accept, we shall have to invoice you for any costs incurred.

Components used in life-support devices or systems must be expressly authorized for such purpose!

Critical components¹ of the Infineon Technologies AG, may only be used in life-support devices or systems² with the express written approval of the Infineon Technologies AG.

- 1 A critical component is a component used in a life-support device or system whose failure can reasonably be expected to cause the failure of that life-support device or system, or to affect its safety or effectiveness of that device or system.
- 2 Life support devices or systems are intended (a) to be implanted in the human body, or (b) to support and/or maintain and sustain human life. If they fail, it is reasonable to assume that the health of the user may be endangered.

Table of Contents		Page
1	Overview	1-1
1.1	Features	1-1
2	Pin Description	2-1
2.1	Pin Configuration	2-1
2.2	Pin Definitions and Functions	2-2
3	Functional Description	3-1
4	Operating Modes	4-1
5	Designing the External Components	5-1
6	Application Note	6-1
7	Electrical Characteristics	7-1
8	Package Outlines	8-1

List of Figures	Page
Figure 2-1 Pin Configuration P-DSO-20-6 (top view)	2-1
Figure 2-2 Pin Configuration P-DSO-20-10 (top view)	2-1
Figure 3-1 Block Diagram	3-1
Figure 5-1 Current limit $I_{Limit,ON}$ as a function of RREF (typical values)	5-1
Figure 5-2 Power Supply Current I_{BAT} as a function of RREF (typical values)	5-2
Figure 5-3 Power Supply Current I_{DD} as a function of RREF (typical values)	5-2
Figure 5-4 Corner frequency of high-pass filter as a function of C_{HP} (typical values)	5-3
Figure 5-5 Time constant of high-pass filter as a function of C_{HP} (typical values)	5-3
Figure 5-6 Delay time of the low-pass filter for the status output signal (typical values)	5-4
Figure 5-7 Delay time of the low-pass filter for the status output signal (typical values)	5-4
Figure 6-1 Application Circuit	6-1
Figure 7-1 Power Dissipation and Reference Voltage Output.	7-6
Figure 7-2 Maximal Line Currents	7-7
Figure 7-3 Resistances	7-7
Figure 7-4 Line Status	7-8
Figure 7-5 Line Status under Superimposed Longitudinal Current	7-8
Figure 7-6 Timing-Characteristics	7-9
Figure 7-7 Lightning Voltage Influence	7-10

List of Tables

Page

Table 2-1	Pin Definitions and Functions P-DSO-20-6	2-2
Table 2-2	Pin Definitions and Functions P-DSO-20-10	2-2
Table 7-1	Absolute Maximum Ratings	7-1
Table 7-2	Operating Range	7-2
Table 7-3	Power-Supply	7-3
Table 7-4	DC-Characteristics	7-3
Table 7-5	Indication of Current Limit	7-4
Table 7-6	Timing-Characteristics	7-6

1 Overview

The IHPC is an integrated power controller especially designed for feeding two-wire ISDN-transmission lines. One line can be powered by one IHPC. An external resistor defines the value of the current-limit for the line. Powering can be switched on or off by the logic inputs "PFEN" and "PFENQ". With a logic low at the "APFI" output the IHPC signals that current-limiting is active; this signal is low-pass filtered. An external capacitor defines the corner frequency of this low-pass filter and the resulting delay time respectively. A second external capacitor is needed to make sure that longitudinal disturbances (AC) will not produce a current limiting effect. Line current-limiting and reducing this limiting level in case of overtemperature guards the IHPC against overloads.



ISDN High Voltage Power Controller IHPC

PEB 2026

Version 1.1

CMOS

1.1 Features

- Battery voltage up to 130 V
- Supplies power for one transmission line
- Current limiting and chip temperature control
- Limiting current can be programmed by an external resistor
- Automatically reduced feeding current in case of overtemperature
- Reliable 170 V Smart Power Technology (SPT 170)
- Small P-DSO-20 package

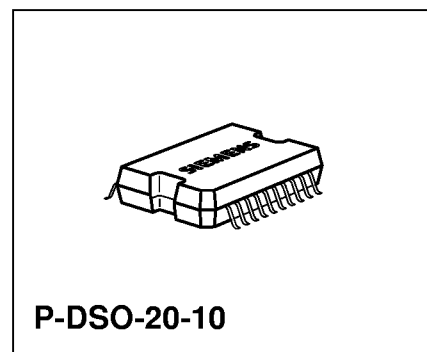
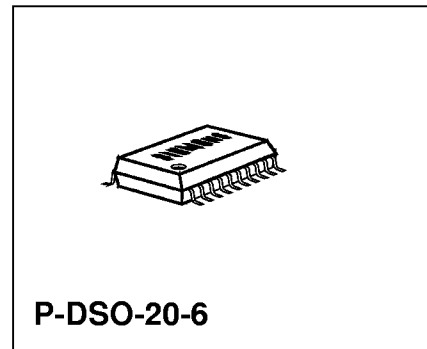

Type	Package
PEB 2026	P-DSO-20-6
	P-DSO-20-10

2 Pin Description

2.1 Pin Configuration

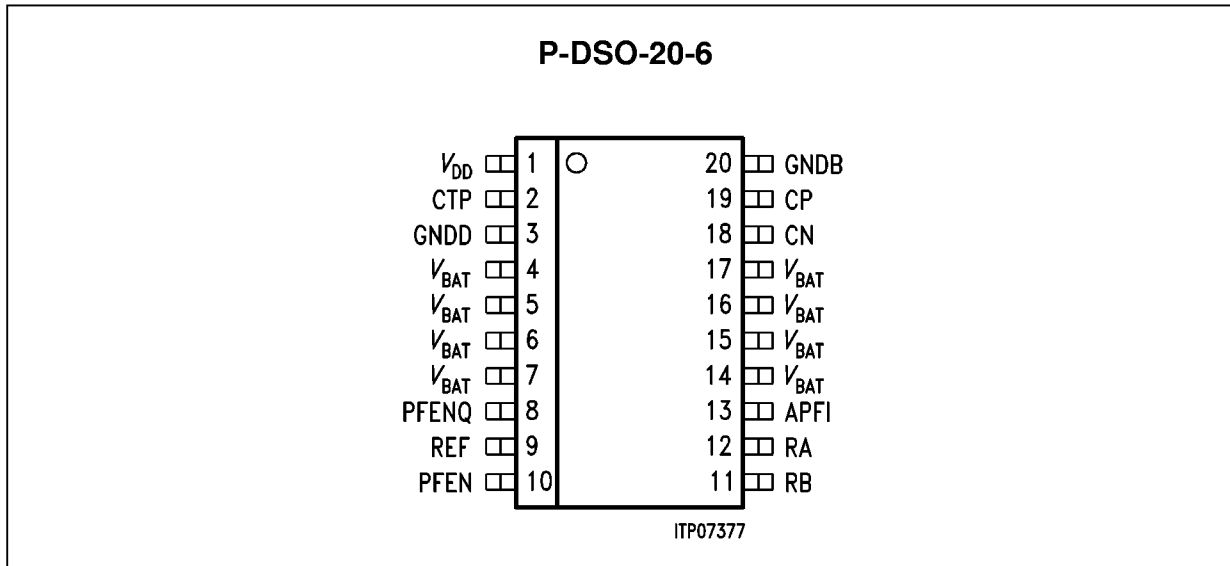

Figure 2-1 Pin Configuration P-DSO-20-6 (top view)

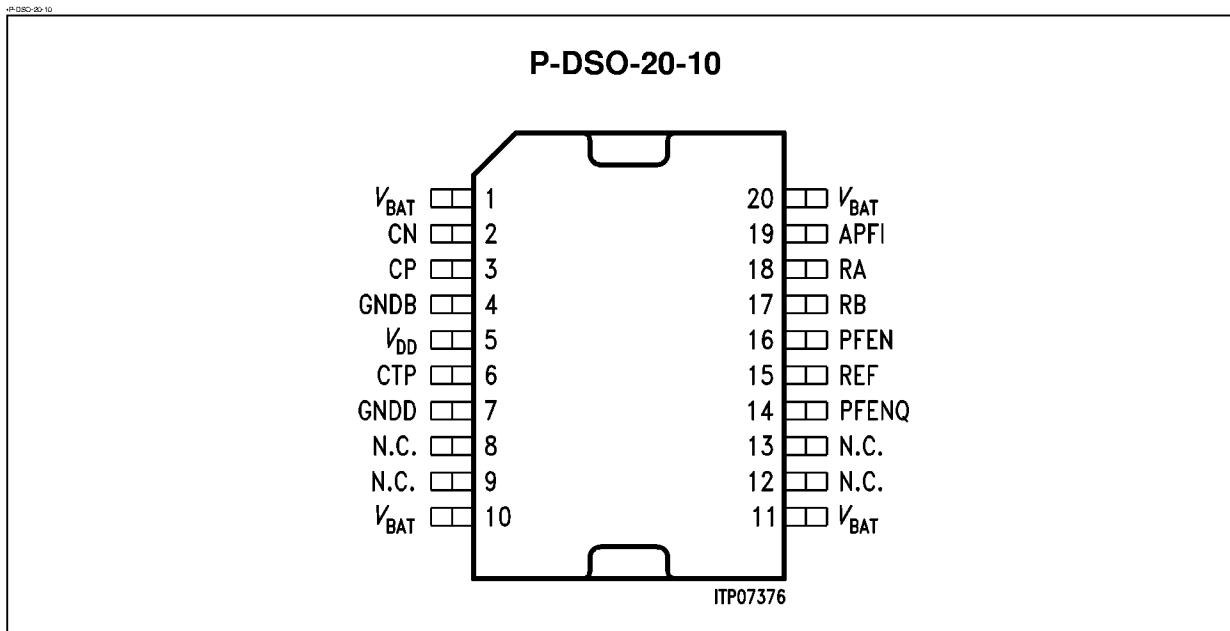

Figure 2-2 Pin Configuration P-DSO-20-10 (top view)

2.2 Pin Definitions and Functions

Table 2-1 Pin Definitions and Functions P-DSO-20-6

Pin	Symbol	Type	Description
4-7, 14-17	V_{BAT}	Supply	Negative battery supply voltage (– 100 V), referred to GNDB
20	GNDB	Supply	Battery ground: RB and RA refer to this pin
1	V_{DD}	Supply	Positive supply voltage (+ 5 V), referred to GNDD
3	GNDD	Supply	Digital ground: V_{DD} , REF, CP, CN, CTP, PFEN, PFENQ and APFI refer to this pin
9	REF	O	Reference output, connected to GNDD via a resistor
19	CP	O	Positive pole of the external capacitor C_{HP}
18	CN	I	Negative pole of the external capacitor C_{HP}
2	CTP	O	Positive pole of the external capacitor C_{TP}
11	RB	O	Output for powering line b (tip), current sensing
12	RA	O	High voltage output for powering line a (ring), current limiting/switching
10	PFEN	I	Logic high on this pin switches on the current feeding
8	PFENQ	I	Logic low on this pin switches on the current feeding
13	APFI	O	Logic low on this pin signals active current-limiting

Table 2-2 Pin Definitions and Functions P-DSO-20-10

Pin	Symbol	Type	Description
1,10, 11,20	V_{BAT}	Supply	Negative battery supply voltage (– 100 V), referred to GNDB
4	GNDB	Supply	Battery ground: RB and RA refer to this pin
5	V_{DD}	Supply	Positive supply voltage (+ 5 V), referred to GNDD
7	GNDD	Supply	Digital ground: V_{DD} , REF, CP, CN, CTP, PFEN, PFENQ and APFI refer to this pin
15	REF	O	Reference output, connected to GNDD via a resistor
3	CP	O	Positive pole of the external capacitor C_{HP}
2	CN	I	Negative pole of the external capacitor C_{HP}
6	CTP	O	Positive pole of the external capacitor C_{TP}
17	RB	O	Output for powering line b (tip), current sensing

Table 2-2 Pin Definitions and Functions P-DSO-20-10 (cont'd)

Pin	Symbol	Type	Description
18	RA	O	High voltage output for powering line a (ring), current limiting/switching
16	PFEN	I	Logic high on this pin switches on the current feeding
14	PFENQ	I	Logic low on this pin switches on the current feeding
19	APFI	O	Logic low on this pin signals active current-limiting

3 Functional Description

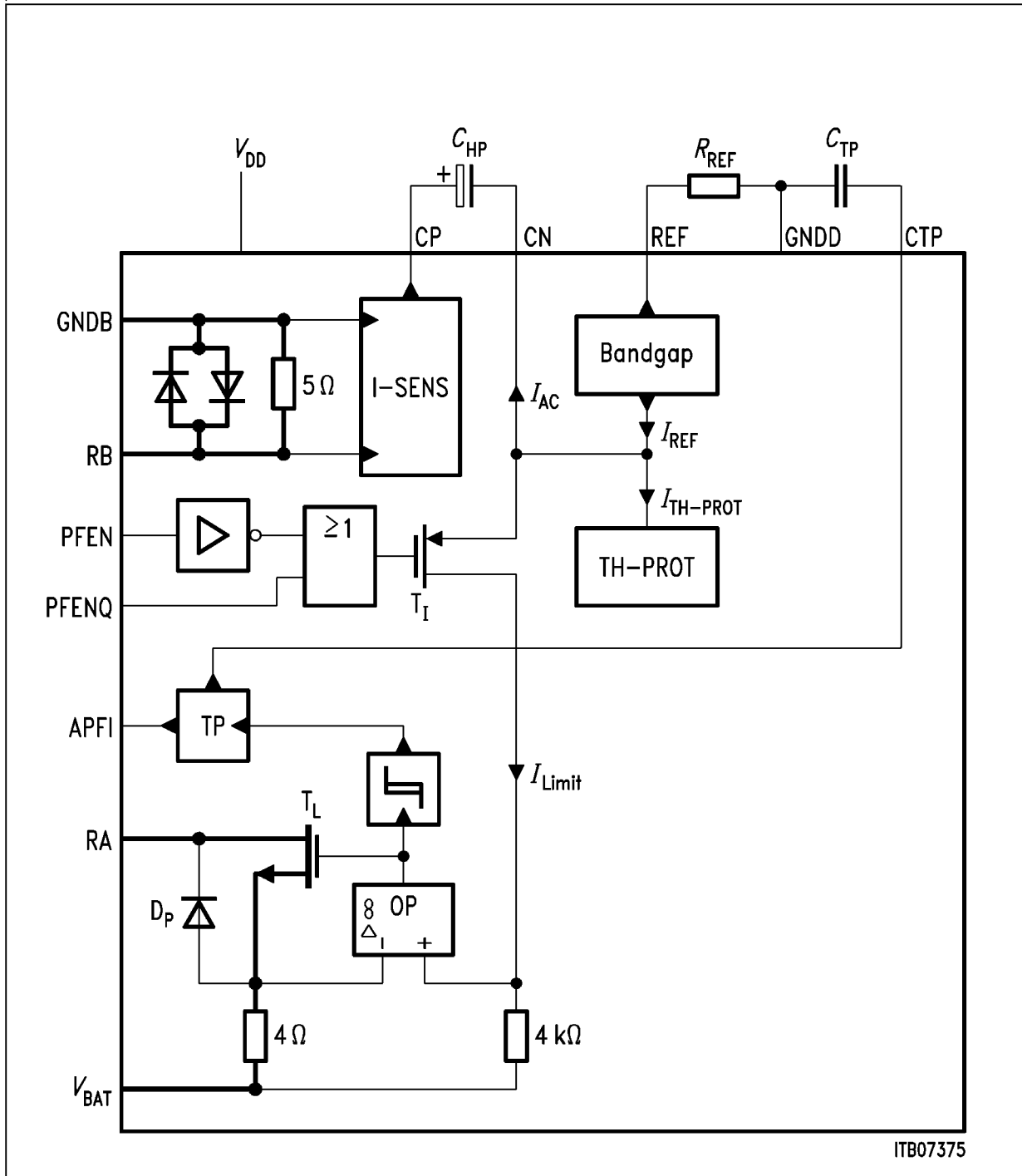

Figure 3-1 Block Diagram

The current flowing from GNDB to RB is measured. A down scaled image of this current is filtered by a high-pass filter with a corner frequency f_{CHP} of approximately 3 Hz (see

Functional Description

Figure 5-4). This filter needs the external capacitor C_{HP} . This “AC”-current is subtracted from the reference-current generated in the bandgap. The value of the reference-current is defined by the external resistor R_{REF} .

In case of overtemperature the thermal protection TH-PROT sinks a current, so that the current I_{Limit} is reduced. So in case of high power dissipation on chip the junction temperature is limited to about 165 °C.

This function is a protection against instant damages due to overload at the outputs. Continuous high temperatures during operation, however, will reduce the life time of the IHPC. A maximum junction temperature of 150 °C shall not be exceeded (See section 7, "Electrical Characteristics")

Measures have to be taken to switch off the IHPC in case of a short-circuit. E.g. if pin APFI indicates active current-limiting, the IHPC should be deactivated after 1.5 sec using pin PFEN or PFENQ. A consecutive power-up attempt shall give enough time to the IHPC to cool down again (e.g. 30 sec).

The current I_{Limit} is reflected to the output current I_{Line} flowing from RA to V_{BAT} using the operational-amplifier OP, the transistor T_L and two resistors (4 Ω, 4 kΩ).

$$I_{Line,max}(t) = 1000 \times I_{Limit}(t) = 1000 \times (I_{REF} - I_{TH-PROT}(t) - I_{AC}(t))$$

In case of “no current-limiting” the output voltage of the operational-amplifier OP is equal to the positive OP-supply voltage. The transistor T_L is “switched on”.

If the output current I_{Line} rises to $I_{Line,max}$ the current-mirror becomes active and keeps the output current at this level.

The voltage level at the gate of transistor T_L shows the state of the current-limiter (current-limiting active or not). This state-signal is filtered by a low-pass filter and generates the logic output APFI. The external capacitor C_{TP} of this low-pass filter defines the corner frequency and the resulting delay times t_{LIMON} (Spec.-No.: 17) and t_{LIMOFF} (Spec.-No.: 18) respectively.

Summarized, the current sensor I-SENS and the high-pass filter prevent, that a longitudinal disturbance in the frequency range from about ($5 \cdot f_{CHP}$) to about 100kHz result in a current limitation. This applies if the maximum amplitude of the longitudinal current is lower than about half of the current limit (Spec.-No.: 3) defined by the external resistor R_{REF} , see also Spec.-No.: 15 and 16.

There is also another effect from the current sensing and high-pass filtering, which can be seen when changing from status LIMOFF to LIMON. This can occur by switching power on to the line (loading the line capacitor) or in case of short-circuiting the line. The resulting current transient starts at half of $I_{Line,max}$ and increases (capacitor loading function) to $I_{Line,max}$ with a time constant t_{CHP} also defined by the value of C_{HP} .

Functional Description

The diodes connected to GNDB and RB protect the IHPC against lightning and overvoltages (see **Absolute Maximum Ratings**). The diode D_p is the parasitic bulk-drain-diode of the DMOS-transistor T_L .

Because of technology reasons („p“-substrate, junction isolation) there are also parasitic diodes from pin V_{BAT} to all other pins.

 I_{BAT} current peak:

When line feeding is switched on (transistor T_L is on) and a short circuit occurs between pins RA and GNDB (or GNDD) then it needs a certain time to unload the gate-source-capacitance of T_L and to limit the current to the defined maximum value. In the meantime a current peak I_{BAT} on the supply voltage V_{BAT} can be seen.

An overvoltage protection circuit for pin RA, for example can produce such a short circuit between pins RA and GNDB.

In the IHPC a fast bipolar npn-transistor limits such current peaks. With $V_{BAT} = 100\text{ V}$, the resulting I_{BAT} current transient has the profile of one triangular pulse with a peak value of about 1.5A and a time duration (50% to 50%) of about 130nsec.

4 Operating Modes

Operating Mode	Status	PFEN	PFENQ	APFI
OFF, powering off		"V _{IL} "	Don't care	"V _{OL} "
OFF, powering off		Don't care	"V _{IH} "	"V _{OL} "
ON, powering on	LIMON, limiter is active	"V _{IH} "	"V _{IL} "	"V _{OL} "
ON, powering on	LIMOFF, limiter isn't active	"V _{IH} "	"V _{IL} "	"V _{OH} "

The logic input pins PFEN and PFENQ are connected to GNDD by integrated current sources. If these pins are not connected externally the logic level is "V_{IL}".

5 Designing the External Components

Resistor R_{REF} :

The value of this resistor defines the current limit $I_{Limit,ON}$ (Spec.-No.: 3) and it will also effect power supply currents I_{BAT} (Spec.-No.: 2) and I_{DD} (Spec.-No.: 1). For typical values of $I_{Limit,ON}$, I_{BAT} and I_{DD} as a function of R_{REF} see the following diagrams.

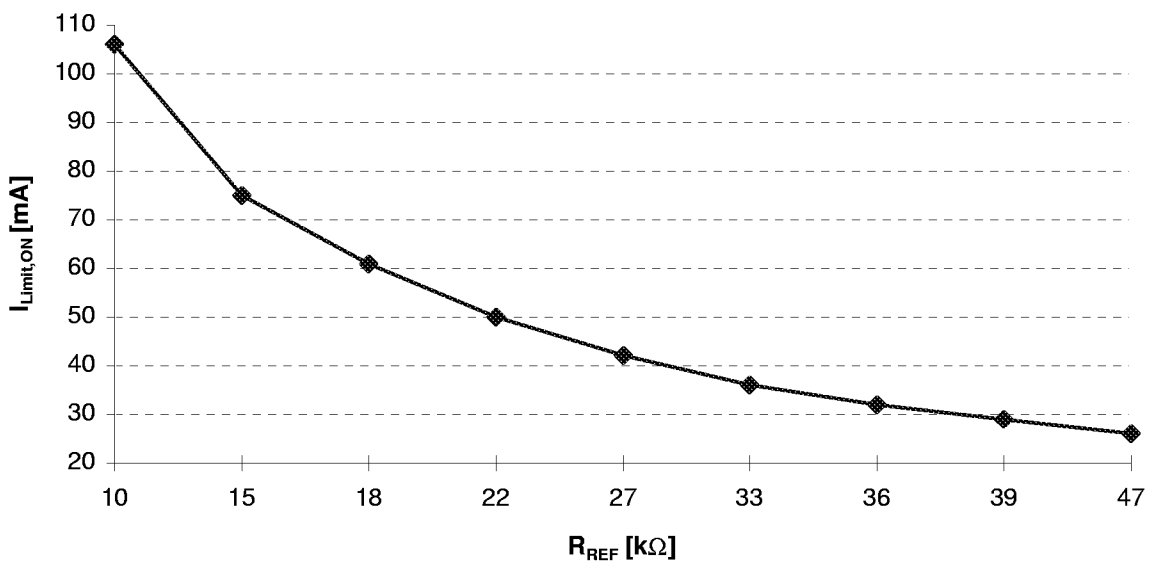

Figure 5-1 Current limit $I_{Limit,ON}$ as a function of R_{REF} (typical values)

Designing the External Components

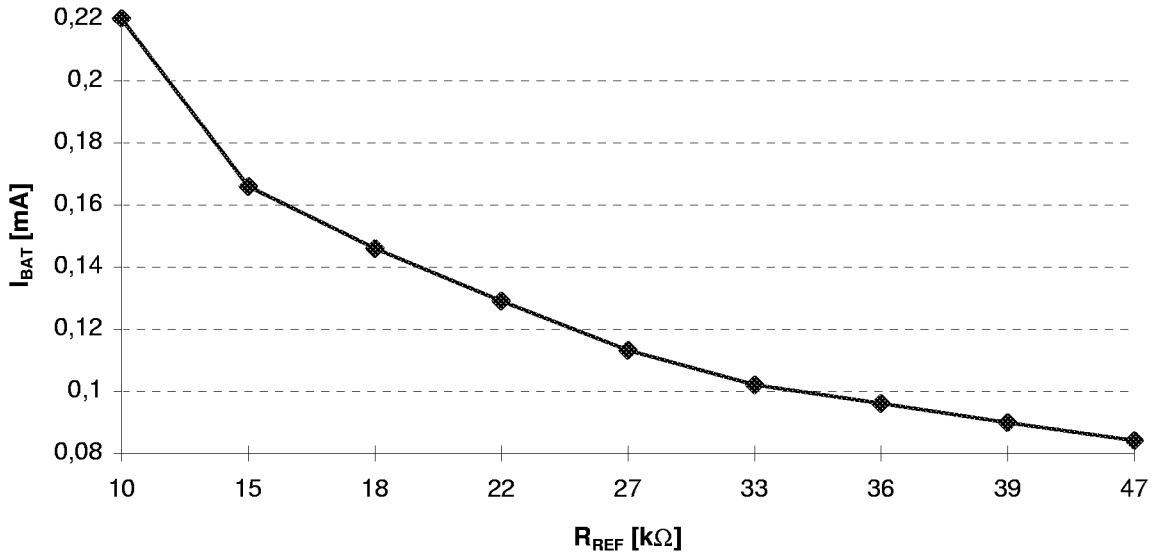

Figure 5-2 Power Supply Current I_{BAT} as a function of R_{REF} (typical values)

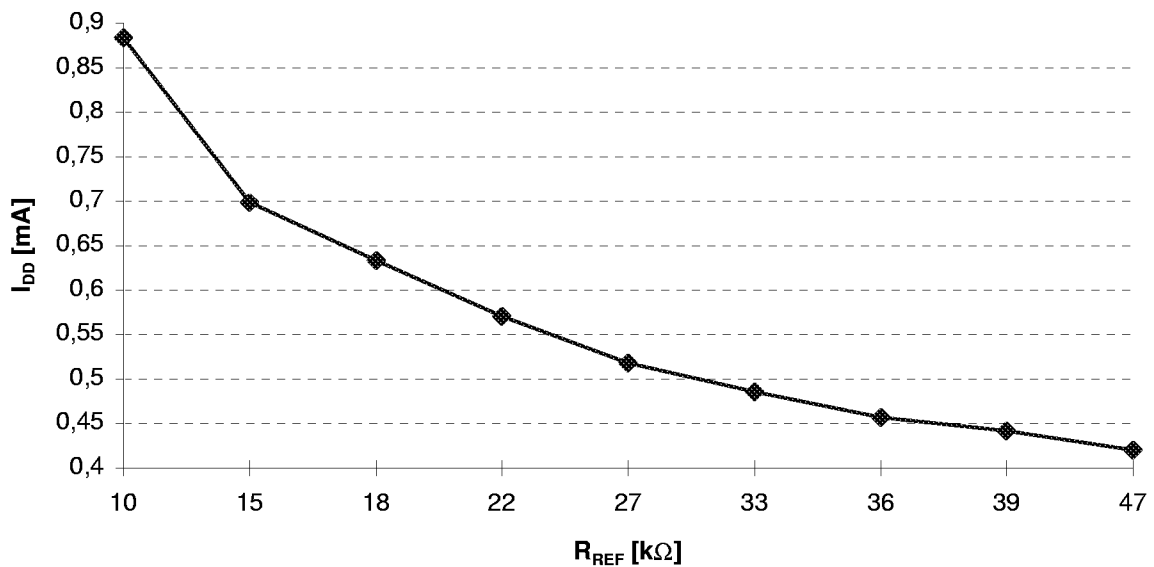

Figure 5-3 Power Supply Current I_{DD} as a function of R_{REF} (typical values)

Capacitor C_{HP} :

The value of this capacitor defines the corner frequency f_{CHP} of the high-pass filter and the time constant t_{CHP} of the current transient described at the last but one paragraph of chapter 2. The following diagrams show typical values of f_{CHP} and t_{CHP} as a function of C_{HP} .

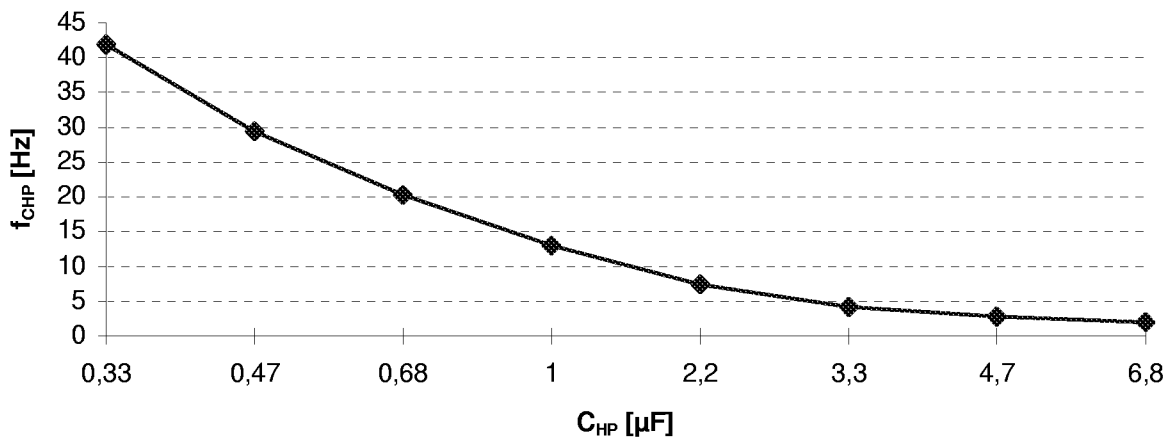

Figure 5-4 Corner frequency of high-pass filter as a function of C_{HP} (typical values)

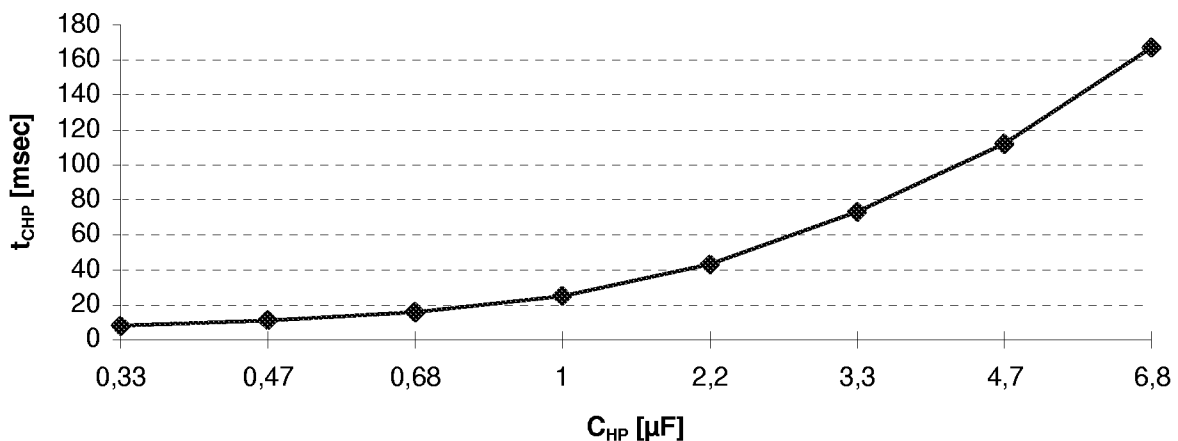

Figure 5-5 Time constant of high-pass filter as a function of C_{HP} (typical values)

Capacitor C_{TP} :

The value of this capacitor defines the corner frequency and the resulting delay times t_{LIMON} (Spec.-No.: 17) and t_{LIMOFF} (Spec.-No.: 18), of the low-pass filter. For typical values of t_{LIMON} and t_{LIMOFF} as a function of C_{TP} see the following diagrams.

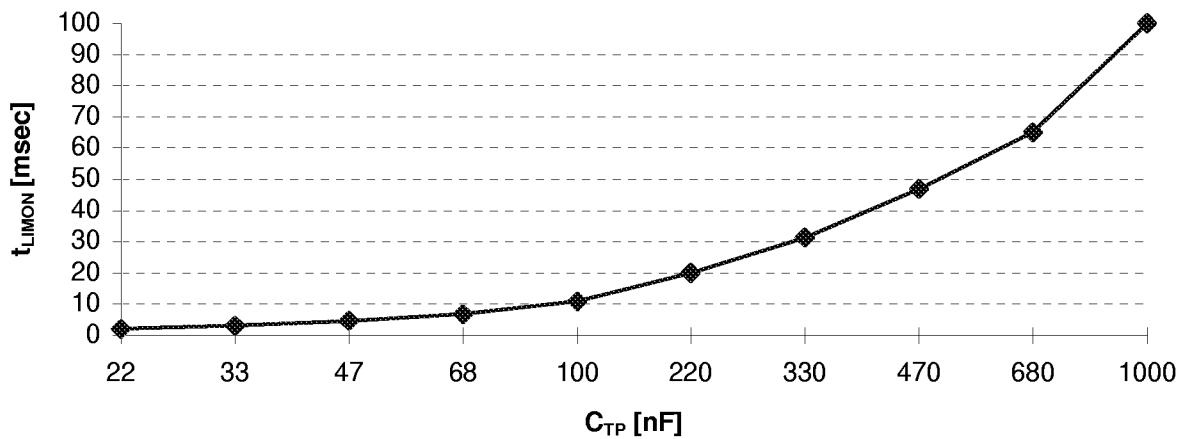

Figure 5-6 Delay time of the low-pass filter for the status output signal (typical values)

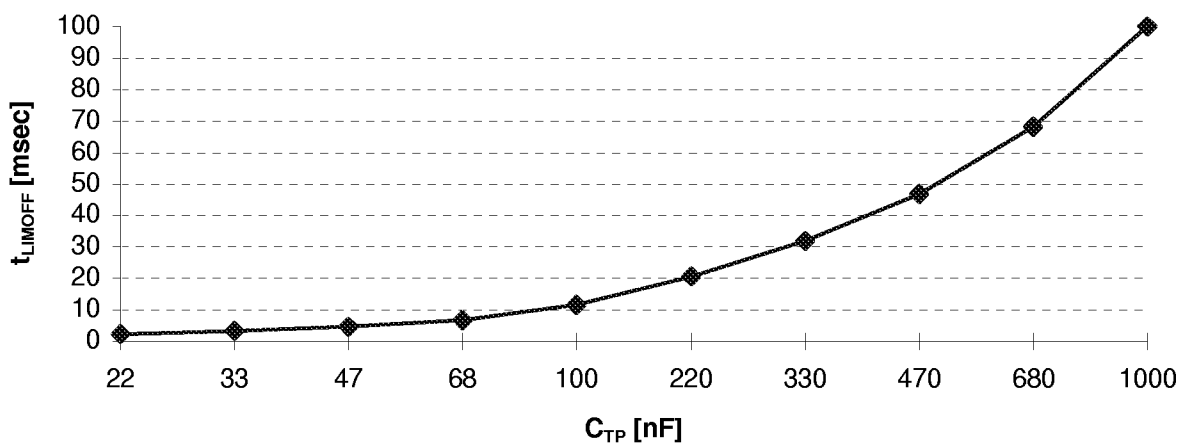

Figure 5-7 Delay time of the low-pass filter for the status output signal (typical values)

6 Application Note

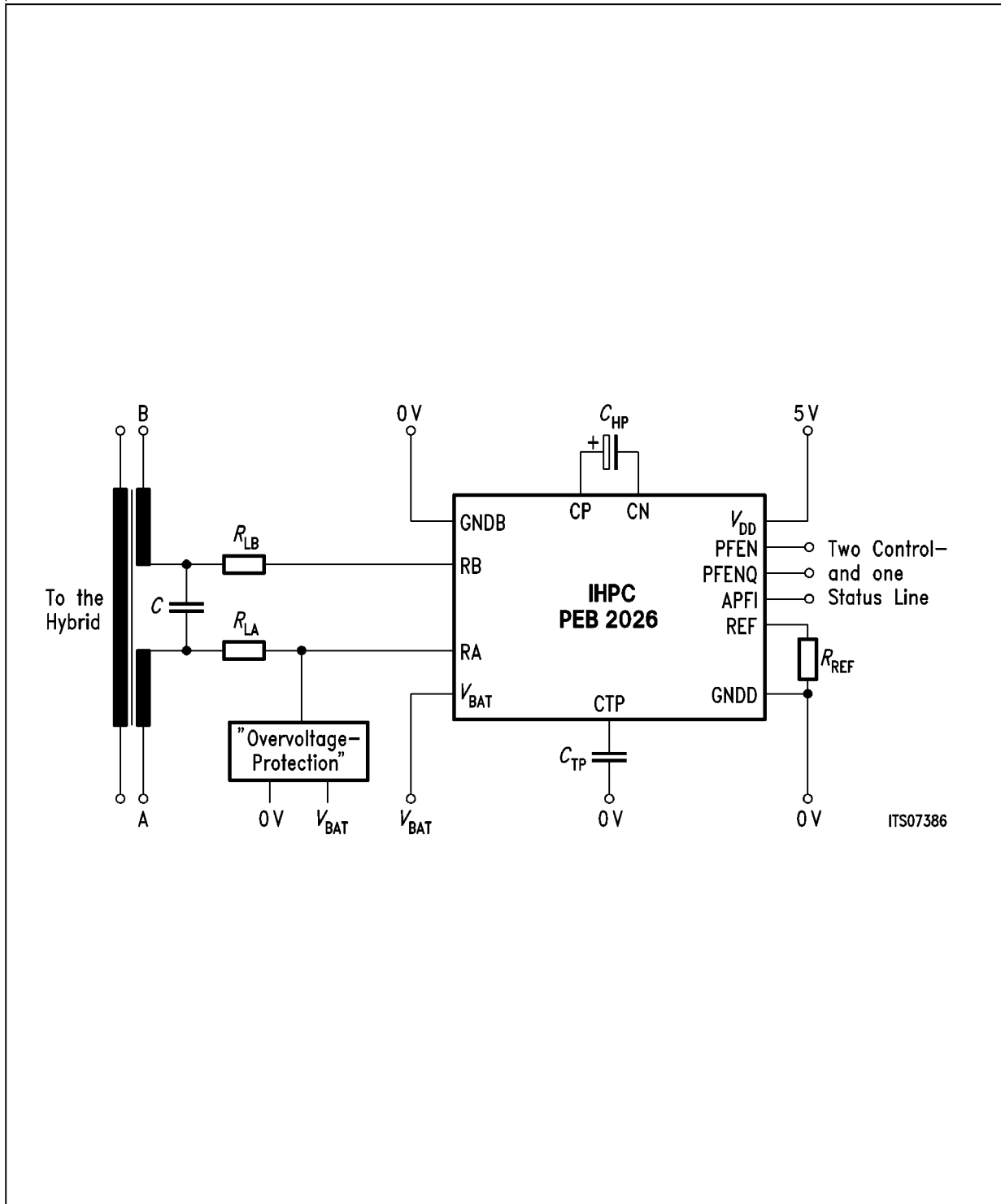

Figure 6-1 Application Circuit

Application Note

R_{REF}	Defines the current-limit and the internal biasing currents. A smaller/bigger value increases/decreases the current limit. It will also effect power supply currents.
C_{TP}	Defines with an internal resistor the delay time (a typical value is 20 msec) from the low pass filter, whose output signal is called 'APFI'. Short disturbances will therefore be filtered. A smaller/bigger value decreases/increases the delay time.
C_{HP}	Defines with an internal resistor the corner frequency from a high pass filter. It is used to make sure that longitudinal disturbances (AC) will not produce a current limiting effect. A smaller/bigger value decreases/increases the corner frequency.
R_{LA}, R_{LB}	These resistors limit the peak currents during lightning transients. The maximum value for these resistors is defined by the allowed voltage drop on the resistors.
C	The AC-signal-current will be shunted by this capacitor.
A, B	A- and B-line to the subscriber
V_{BAT}	The most negative supply voltage; also called battery voltage.
overvoltage protection	This circuit makes sure that the voltage from R_A to V_{BAT} will not exceed the defined limits in case of lightning (see Absolute Maximum Ratings).

Recommended Device Values:

R_{REF}	22 k Ω , Current limiting is set to 50 mA
C_{TP}	220 nF, 'APFI' delay time is set to 20 msec
C_{HP}	4.7 μ F, AC longitudinal disturbances in a frequency range higher than 16.666 Hz do not effect a current limiting.
R_{LA}, R_{LB}	23 Ω , Minimum value, so that peek currents don't exceed 16 A (using voltage peek = 1 kV from 40 Ω source resistance) in case of lightning.

7 Electrical Characteristics

Table 7-1 Absolute Maximum Ratings

Parameter	Symbol	Limit Values		Unit	Test Condition
		min.	max.		
Battery voltage	V_{BAT}	- 150	0.5	V	Referred to GNDB
V_{DD} supply voltage	V_{DD}	- 0.5	6	V	Referred to GNDD
Ground voltage difference	$V_{GNDB} - V_{GNDD}$	- 0.5	0.5	V	
Ground pulse voltage difference	$V_{GNDB} - V_{GNDD}$	- 1	1	V	$t_{max} = 1$ msec
Junction temperature	T_j		150	°C	
Voltages on logic inputs PFEN, PFENQ	V_{PFEN}, V_{PFENQ}	- 0.3	$V_{DD} + 0.3$	V	Referred to GNDD
Voltages on REF	V_{REF}	- 0.3	$V_{DD} + 0.3$	V	Referred to GNDD
Voltages on CP	V_{CP}	- 0.3	$V_{DD} + 0.3$	V	Referred to GNDD
Voltages on CN	V_{CN}	- 0.3	$V_{DD} + 0.3$	V	Referred to GNDD
Voltages on CTP	V_{CTP}	- 0.3	$V_{DD} + 0.3$	V	Referred to GNDD
Voltages on logic output APFI	V_{APFI}	- 0.3	$V_{DD} + 0.3$	V	Referred to GNDD
RB voltage	V_{RB}	- 0.5	+ 0.5	V	Referred to GNDB
RB pulse current	I_{RB} (into pin RB)	- 8	8	A	$t_{max} = 1$ msec
RB peak current	I_{RB_peak}	- 16	16	A	See figure 7-7
RA voltages	V_{RA}	- 0.3	150	V	Referred to V_{BAT}
RA pulse current	I_{RA} (into pin RA)	- 1	1	A	$t_{max} = 1$ msec
RA pulse voltage	V_{RA_pulse}	- 1	170	V	$t_{max} = 1$ msec, Referred to V_{BAT}
ESD-voltage, all pins			1	kV	Human body model

Note: Maximum ratings are absolute ratings; exceeding only one of these values may cause irreversible damage to the integrated circuit.

Electrical Characteristics

Table 7-2 Operating Range

Parameter	Symbol	Limit Values		Unit	Test Condition
		min.	max.		
Battery voltage	V_{BAT}	- 130	- 30	V	Referred to GNDB
V_{DD} supply voltage	V_{DD}	4.75	5.25	V	Referred to GNDD
Ground voltage difference	$V_{GNDB} - V_{GNDD}$	- 0.3	0.3	V	
Ambient temperature					
PEB 2026	T_A	0	+70	°C	
PEF 2026	T_A	-40	+85	°C	

Static Thermal Resistance

Junction to ambient	$R_{th, jA}$		55	K/W	P-DSO-20-10
Junction to case	$R_{th, jC}$		4	K/W	P-DSO-20-10
Junction to ambient	$R_{th, jA}$		65	K/W	P-DSO-20-6
Junction to pins	$R_{th, jPins}$		15	K/W	P-DSO-20-6

Note: In the operating range the functions given in the circuit description are fulfilled.

The power package P-DSO-20-10 has an exposed copper-heatspreader with a high thermal capacitance. For power feeding to ISDN-lines which are in a fault condition (e.g. short circuit) the maximum power dissipation on chip will become V_{BAT} supply voltage times limiting current (e.g.: $100V \cdot 50mA = 5W$). It is necessary to try to feed the line for about 2 seconds under this condition (5W), then the feeding can be switched off but must be switched on again about 30 seconds later. In this application the thermal capacitance of the cooper-heatspreader helps to keep the maximum chip temperature below the thermal protection temperature level (165°C). No extra heatsink is necessary.

The small P-DSO-20-6 package is applicable if the device is mounted on a pcb having at least 900 mm² copper area close to the device. The pcb serves as heat sink, heat flowing off through the pins, particularly the Vbat pins. With a mounting like this, the IHPC performs as follows: a current of 50 mA is supplied for 5 sec, while the device is shorted to Vbat=100V. At an ambient temperature of 70°C the current pulse may be periodically repeated with a period of 32 sec.

Electrical Parameters

Typical values are defined at the following test conditions:

$$V_{DD}=5V \pm 1 \% C_{HP}=4.7\mu F \pm 10 \% (6.3 V)$$

$$V_{BAT}=-100V \pm 1 \% C_{TP}=220nF \pm 10 \% (6.3 V)$$

$$R_{LA}=23\Omega \pm 1 \% T_A=25 \pm 5 \text{ } ^\circ\text{C}$$

$$R_{LB}=23\Omega \pm 1 \% R_{Line}=\pm 0.1 \%$$

$$R_{REF}=22k\Omega \pm 1 \% \text{no heatsink}$$

Min. and max. values are in force within the whole operating range.

Table 7-3 Power-Supply

No.	Parameter	Symbol	Limit Values			Unit	Test Condition	Test Fig.	Mode
			min.	typ.	max.				

Supply Currents ($I_{RB} = I_{RA} = 0$)

1	V_{DD} current	I_{DD}		0.57	0.9	mA		7-1	all
2	V_{BAT} current	I_{BAT}		0.13	0.25	mA		7-1	all

Table 7-4 DC-Characteristics

No.	Parameter	Symbol	Limit Values			Unit	Test Condition	Test Fig.	Mode
			min.	typ.	max.				

Maximal Line Currents

3	Line current	$I_{limit,ON}$	45	50	55	mA		7-2	ON, Sta- tus: LIMON
4	Line current	$I_{max,OFF}$		0	10	μA		7-2	OFF

Logic Input Levels on PFEN and PFENQ

5	H-input voltage	V_{IH}	2			V			all
6	L-input voltage	V_{IL}			0.8	V			all
7	Input current	I_{inp}	2	11	20	μA	$0.8 V \leq V_{inp} \leq V_{DD}$		all

Electrical Characteristics

Table 7-4 DC-Characteristics (cont'd)

No.	Parameter	Symbol	Limit Values			Unit	Test Condition	Test Fig.	Mode
			min.	typ.	max.				

Logic Output Levels on APFI

8	H-output voltage	V_{OH}	$V_{DD} - 0.4$			V	$I_{Source} = 100 \mu A$		ON
9	L-output voltage	V_{OL}			0.4	V	$I_{Sink} = 100 \mu A$		ON, OFF

Resistance from GNDB to R_B

10	R: GNDB to RB	R_{RB}	3	5	7	Ω	$I_{RB} = 30 \text{ mA}$ $\pm 5 \%$	7-3	ON, OFF
----	---------------	----------	---	---	---	----------	--	-----	------------

ON-resistance from R_A to V_{BAT}

11	ON-R: RA to V_{BAT} (T_L - R_{on} included)	R_{RA}	2.65	5	7.35	Ω	$I_{RA} = 30 \text{ mA}$ $\pm 5 \%$	7-3	ON, Status: LIMOFF
----	--	----------	------	---	------	----------	--	-----	--------------------------

Difference-resistance between R_{RA} and R_{RB}

12	$R_{RA} - R_{RB}$ PEB 2026 PEF 2026	R_{DIFF}	-0.35	0	0.35	Ω			ON, Status: LIMOFF
			-0.40	0	0.40	Ω			

Table 7-5 Indication of Current Limit

No.	Parameter	Symbol	Mode	Test Condition	Status	Test Fig.
-----	-----------	--------	------	----------------	--------	-----------

Indication of Current Limit

13	Line Status	S_{LIMON}	ON	$R_{Line} = 1762 \Omega$	LIMON, $APFI = V_{OL}$	7-4
14	Line Status	S_{LIMOFF}	ON	$R_{Line} = 2166 \Omega$	LIMOFF, $APFI = V_{OH}$	7-4

Table 7-5 Indication of Current Limit (cont'd)

No.	Parameter	Symbol	Mode	Test Condition	Status	Test Fig.
-----	-----------	--------	------	----------------	--------	-----------

Indication of Current Limit under Superimposed Longitudinal Current

15	Line Status	S_{LLIMON}	ON	$R_{Line} = 1482 \Omega$	LIMON, APFI = V_{OL}	7-5
16	Line Status	$S_{LLIMOFF}$	ON	$R_{Line} = 2801 \Omega$	LIMOFF, APFI = V_{OH}	7-5

Calculation and Values of R_{Line}

$$R_{Line} = \frac{V_{BAT}}{I_{Line}} - R_{RA} - R_{RB} - R_{LA} - R_{LB} = \frac{100V}{I_{Line}} - 5 \Omega - 5 \Omega - 23 \Omega - 23 \Omega$$

where:

R_{LA} , R_{LB} ... referred to page 7-3, electrical parameters

R_{RA} , R_{RB} ... referred to Spec.-No.: 10 and 11

I_{Line}	R_{Line}
35 mA	2801 Ω
45 mA	2166 Ω
55 mA	1762 Ω
65 mA	1482 Ω

Note: In some of these cases the IHPC will limit the line current to lower values.

Table 7-6 Timing-Characteristics

No.	Parameter	Symbol	Limit Values			Unit	Test Condition	Test Fig.	Mode
			min.	typ.	max.				
Delay from Begin/End of Current Limiting to Status LIMON/LIMOFF									
17	Time to LIMON	t_{LIMON}	10	20	30	msec	R_{Line} : $2166 \Omega \rightarrow 1762 \Omega$ \Rightarrow APFI: LIMOFF \rightarrow LIMON	7-6	ON
18	Time to LIMOFF	t_{LIMOFF}	10	20	30	msec	R_{Line} : $1762 \Omega \rightarrow 2166 \Omega$ \Rightarrow APFI: LIMON \rightarrow LIMOFF	7-6	ON

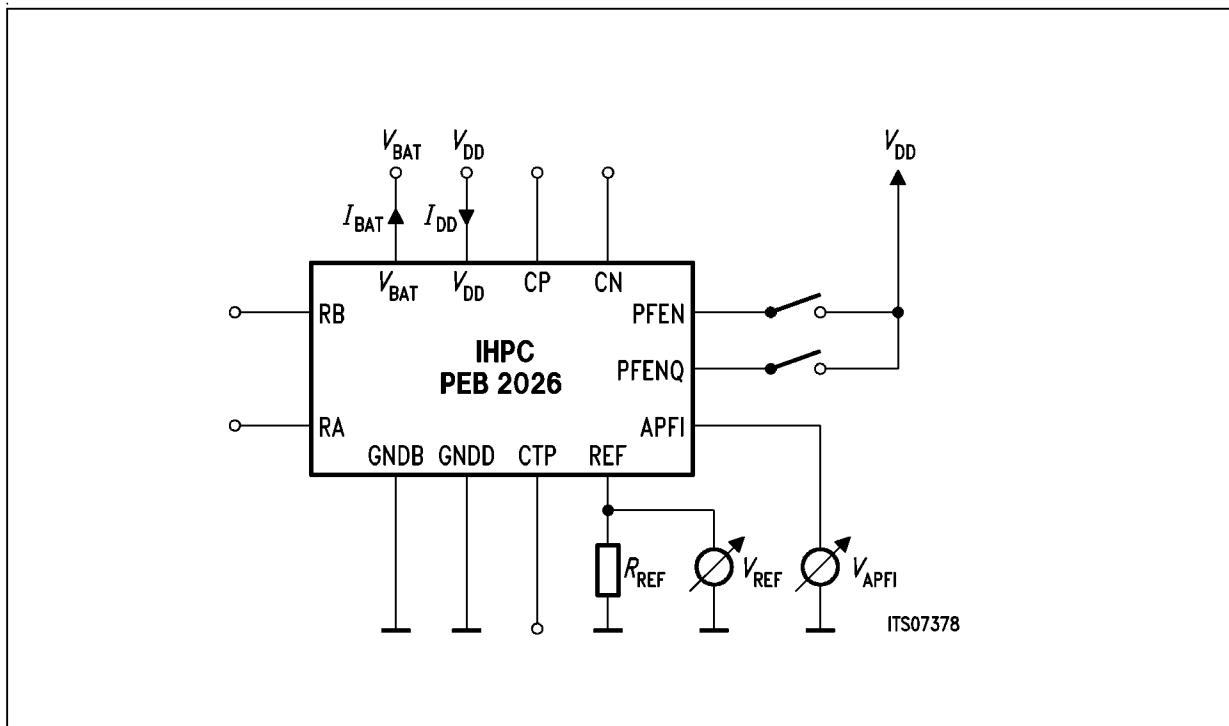

Figure 7-1 Power Dissipation and Reference Voltage Output

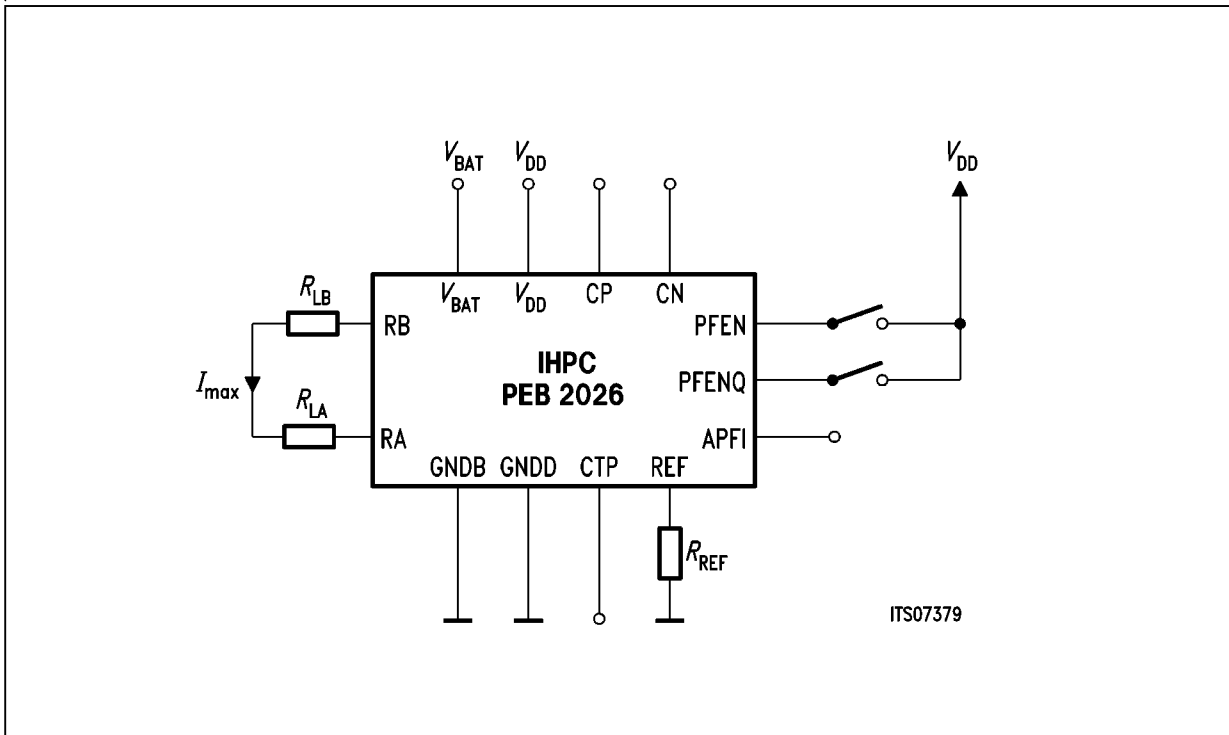

Figure 7-2 Maximal Line Currents

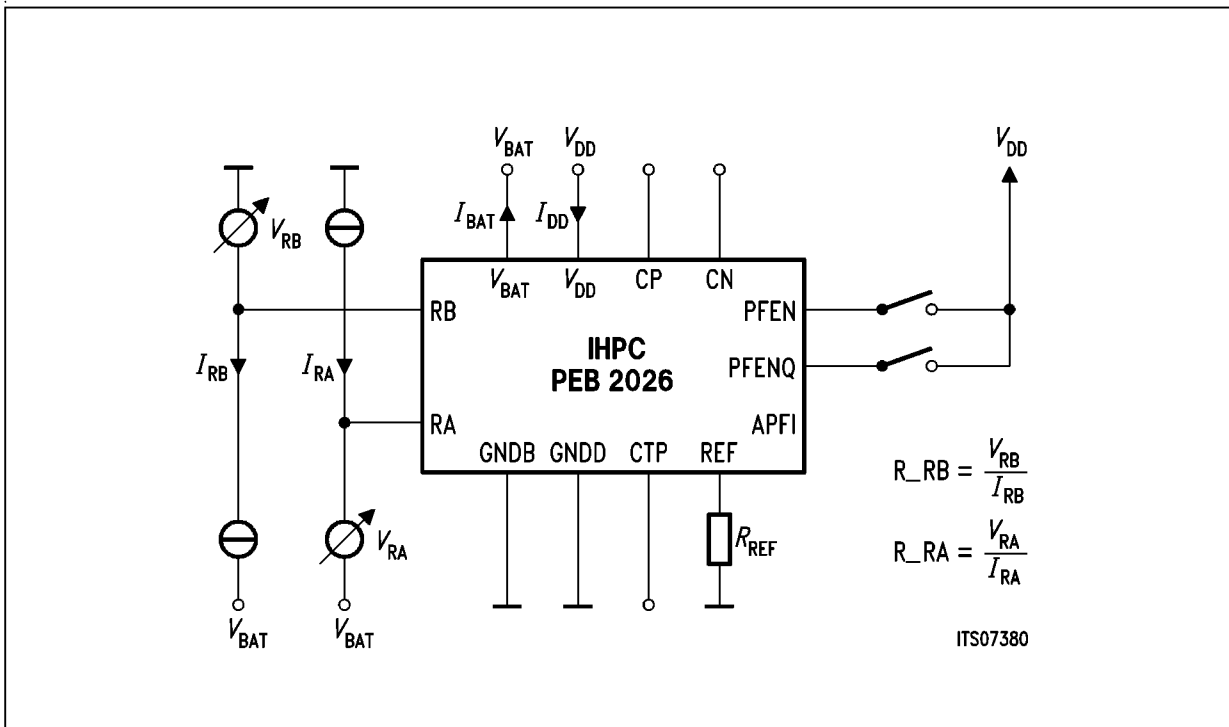

Figure 7-3 Resistances

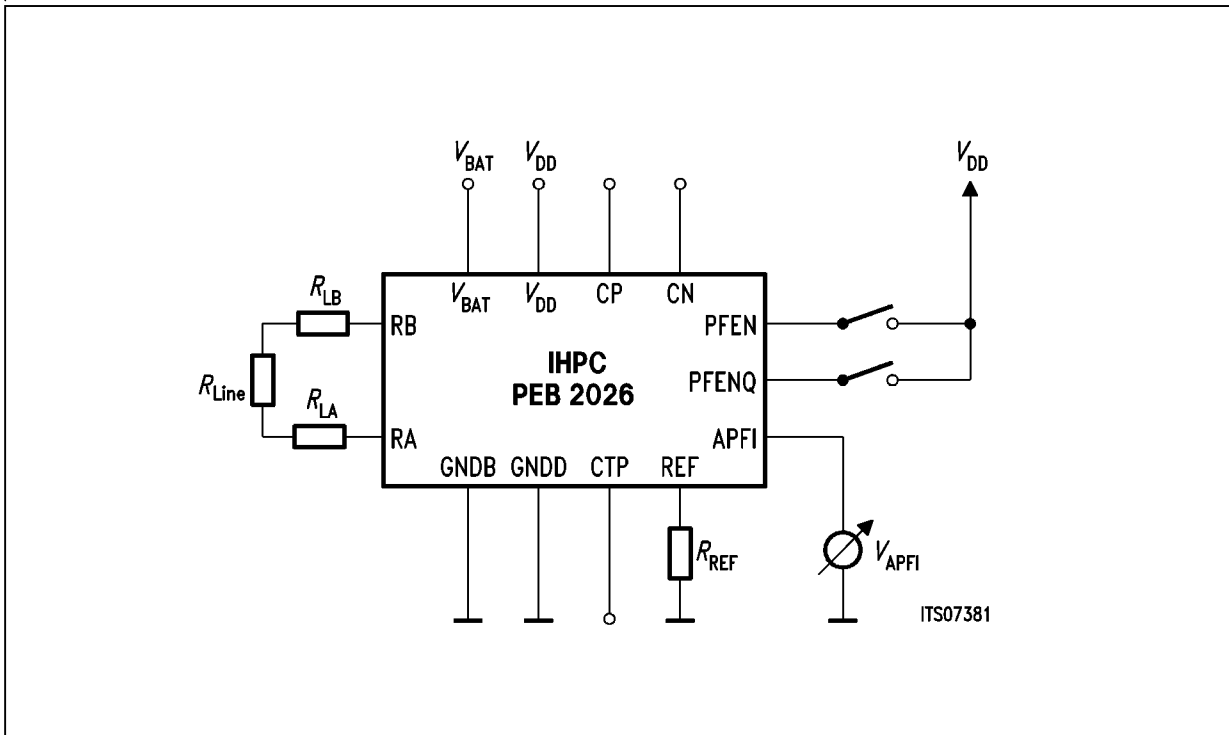

Figure 7-4 Line Status

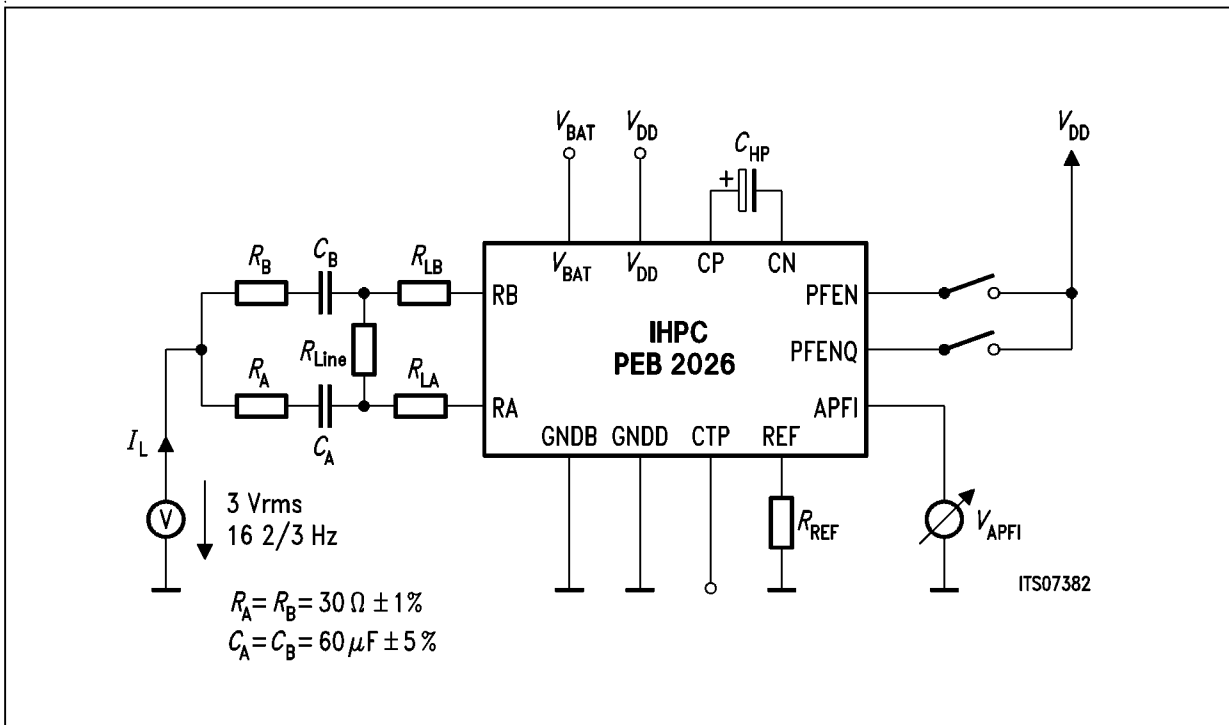

Figure 7-5 Line Status under Superimposed Longitudinal Current

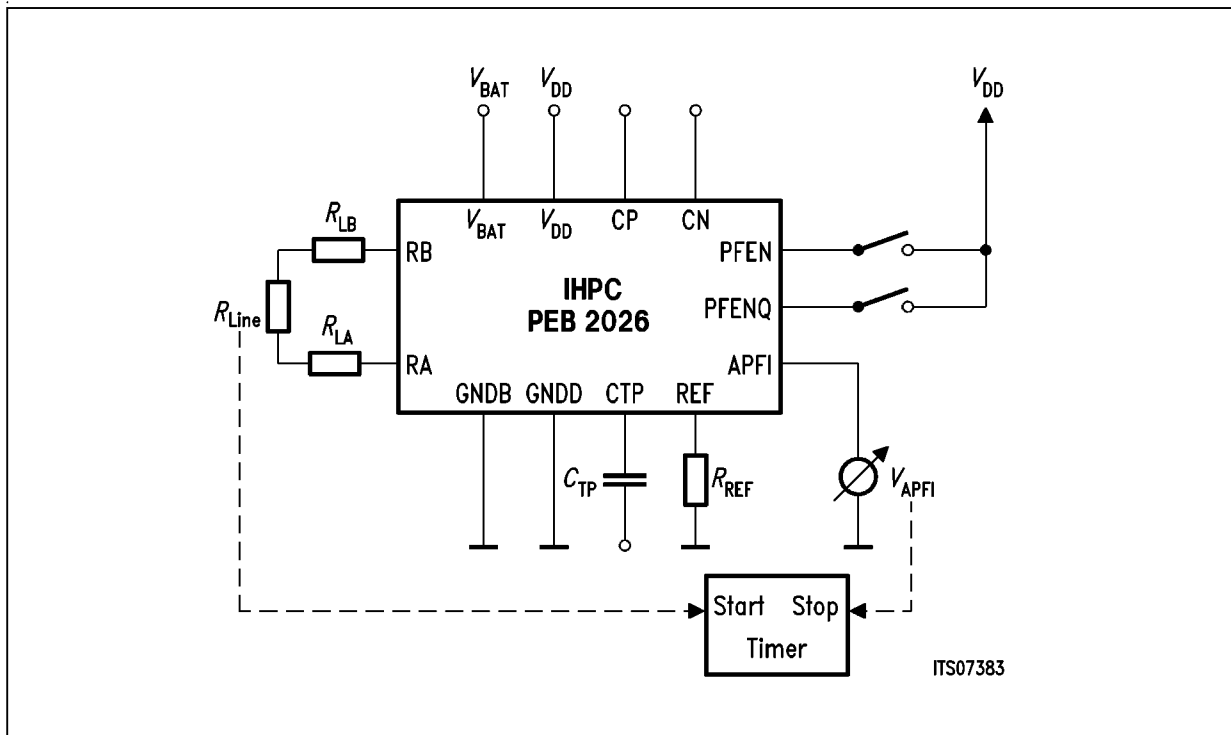

Figure 7-6 Timing-Characteristics

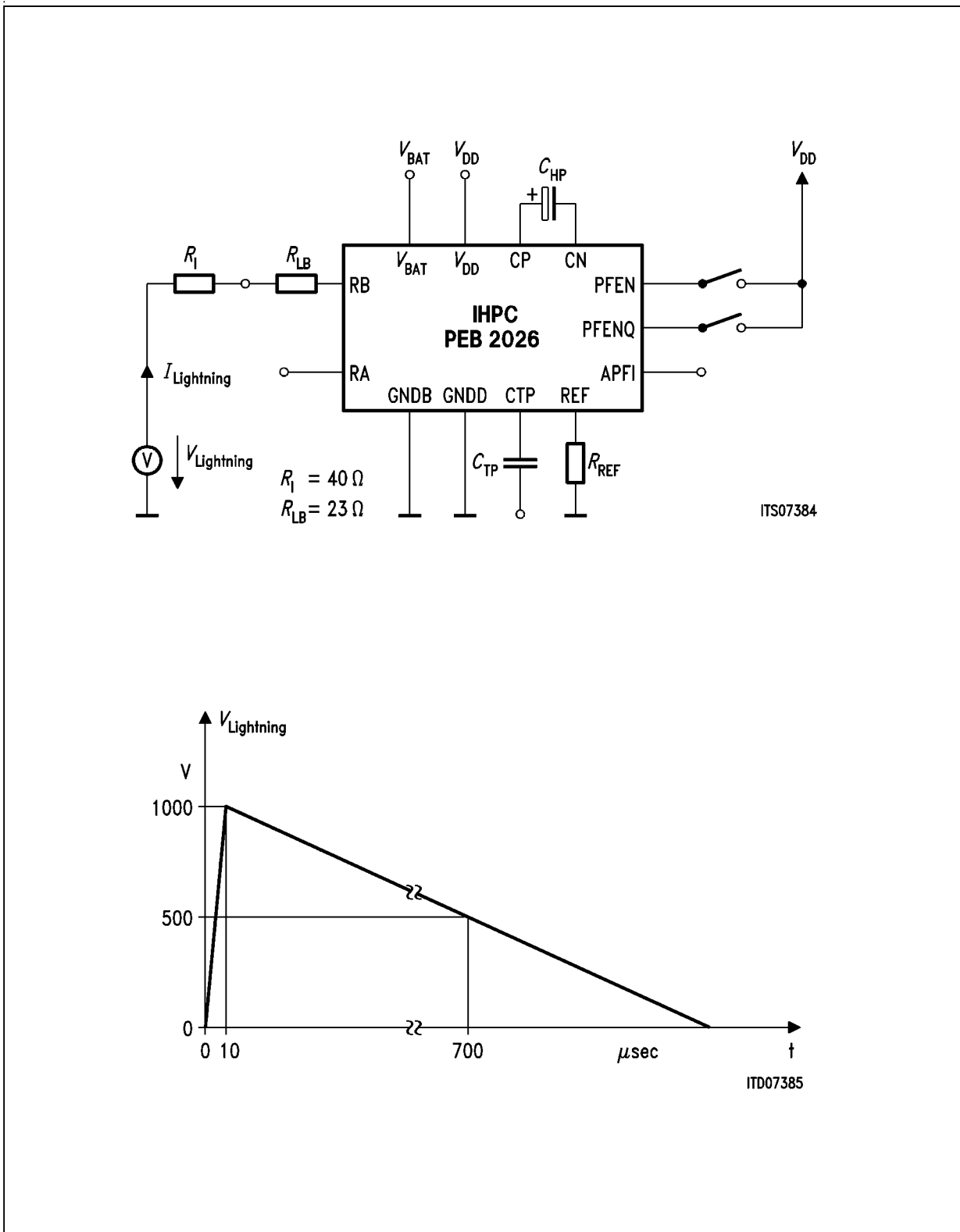
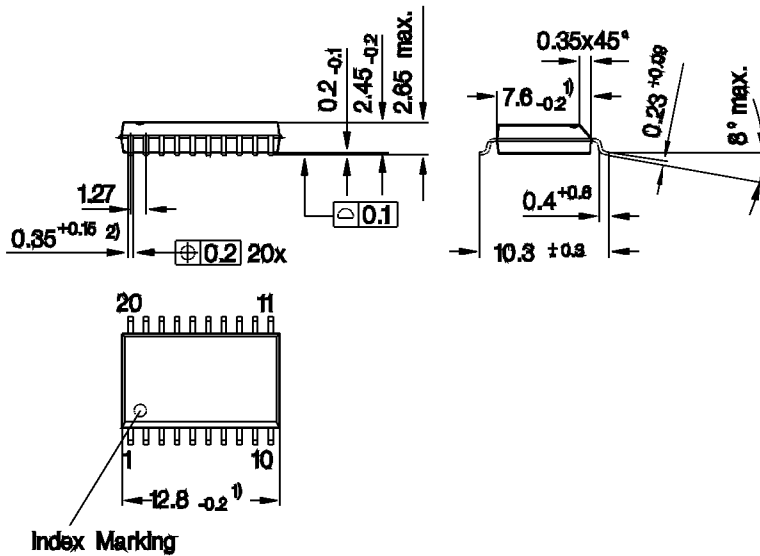

Figure 7-7 Lightning Voltage Influence

8 Package Outlines

P-DSO-20-6 (Plastic Dual Small Outline Package)



Index Marking

- 1) Does not include plastic or metal protrusion of 0.15 max. per side
- 2) Does not include dambar protrusion

GFPS05094

Sorts of Packing

Package outlines for tubes, trays etc. are contained in our

SMD = Surface Mounted Device

Dimensions in mm

P-DSO-20-10
(Plastic Dual Small Outline Package)

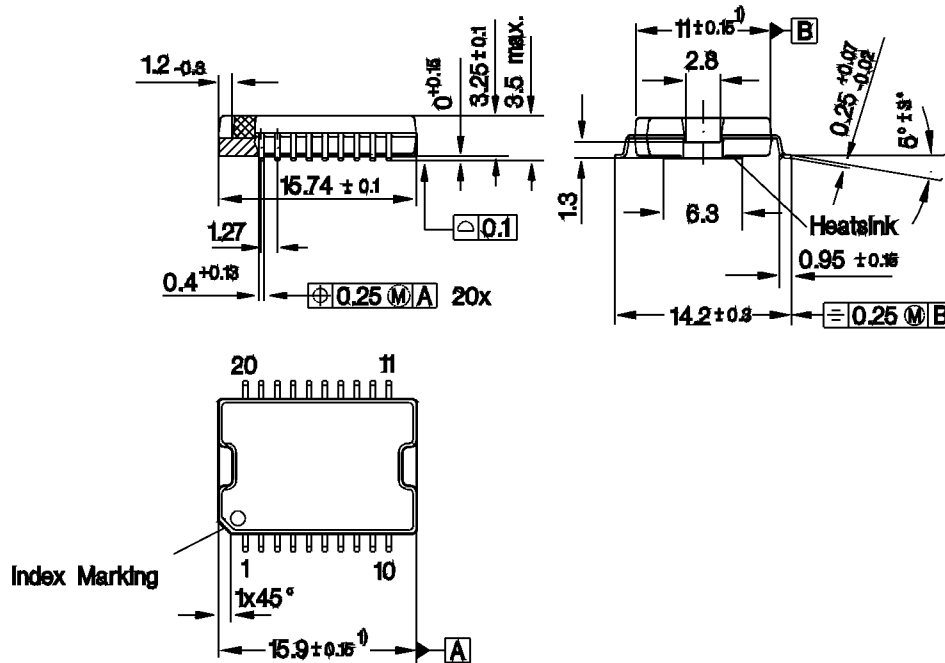

1) Does not include plastic or metal protrusion of 0.15 max. per side

GPS05791

Sorts of Packing

Package outlines for tubes, trays etc. are contained in our

SMD = Surface Mounted Device

Dimensions in mm